

ELEVATE

Reference Drawings & Instructions

Item #894840-XX2

54" Rectangular Canopy

Configuration 2 (For Low Ceilings)

All Glass Options

For specific glass option, refer to style number listed on the bottom of instruction pages.

CUSTOMER REFERENCE DRAWING

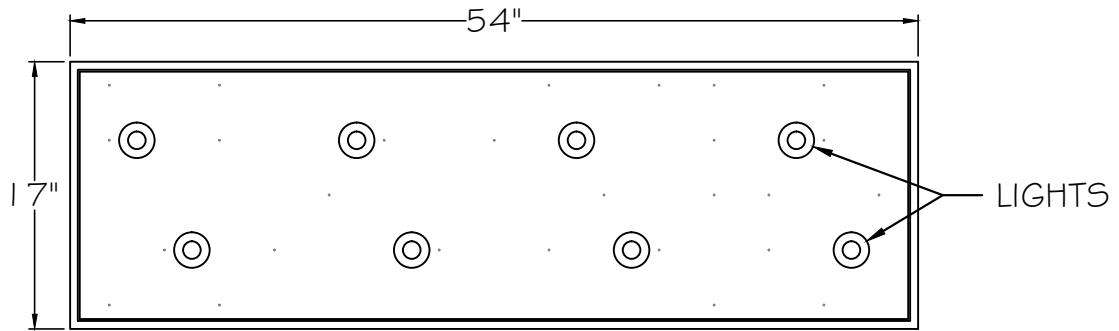



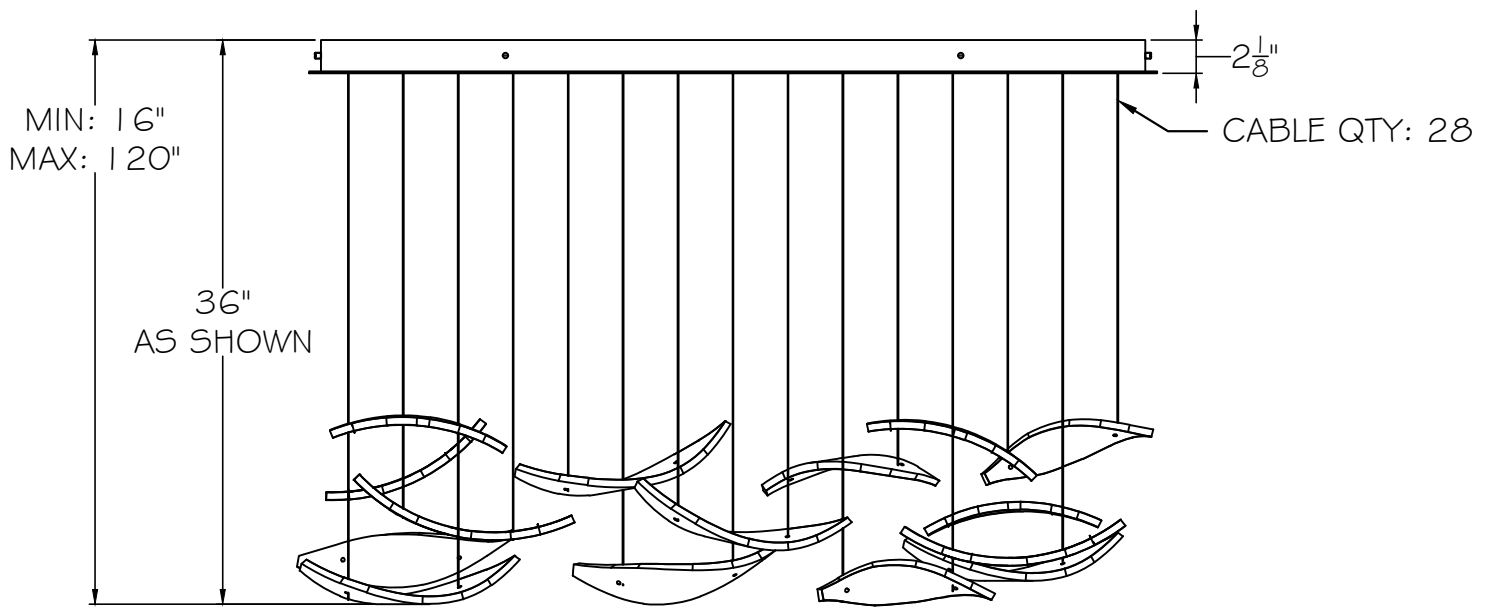



TOP VIEW



FRONT VIEW

CONFIGURATION 2
SHEET 2 OF 2

THUMBNAIL IMAGES OF STYLE OPTIONS:

<p>-112 SILVER -212 GOLD</p>  <p>GLASS PLUME W/ DICHR0 (X15)</p>	<p>-122 SILVER -222 GOLD</p>  <p>GLASS PLUME NO DICHR0 (X15)</p>	<p>-132 SILVER -232 GOLD</p>  <p>GLASS SPIRE CLEAR (X20)</p>	<p>-142 SILVER -242 GOLD</p>  <p>GLASS SPIRE BLACK (X20)</p>	<p>-152 SILVER -252 GOLD</p>  <p>GLASS SPIRE METEORITE (X20)</p>
<p>-162 SILVER -262 GOLD</p>  <p>FROZEN PAGES (FRIT) (X15)</p>	<p>-172 SILVER -272 GOLD</p>  <p>BLANK PAGES (WHITE) (X15)</p>			



This drawing, specifications and the product depicted are the exclusive property of Fine Art Handcrafted Lighting®. In compliance with US copyright and patent requirements, notice is hereby given that this document and the product depicted shall not be copied, altered or used in any manner without the expressed written consent of Fine Art Handcrafted Lighting®.

www.finearthl.com

Tel:(305) 821-3850
FINE ART LAMPS®

Fax:(305) 513-5736

STYLE NUMBER:

894840

DATE:

10/13/2020

INSTRUCTIONS for PLUME GLASS OPTIONS

NOTE: ORIENTATION OF CANOPY IS CRITICAL TO GLASS DROP DESIGN

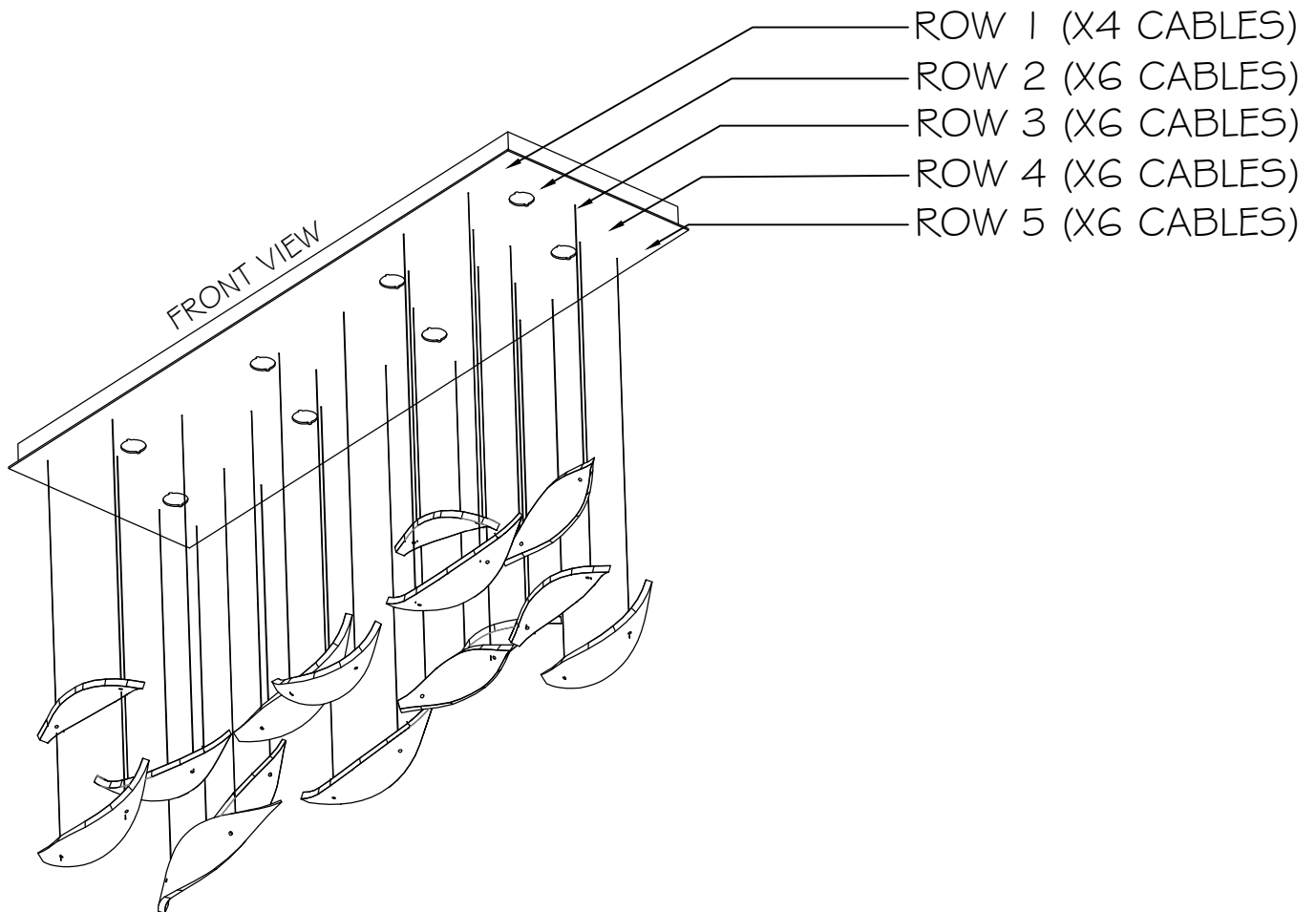

- ROW 1 (X4 CABLES)
- ROW 2 (X6 CABLES)
- ROW 3 (X6 CABLES)
- ROW 4 (X6 CABLES)
- ROW 5 (X6 CABLES)

STYLE(S) #: 894840-112 -212 -122 -222



This drawing, specifications and the product depicted are the exclusive property of Fine Art Handcrafted Lighting®. In compliance with US copyright and patent requirements, notice is hereby given that this document and the product depicted shall not be copied, altered or used in any manner without the expressed written consent of Fine Art Handcrafted Lighting®.

www.finearthl.com

Tel: (305) 821-3850
FINE ART LAMPS®

Fax: (305) 513-5736

INSTRUCTION #:

00791406

SHEET

1 / 7

INSTRUCTIONS for PLUME GLASS OPTIONS

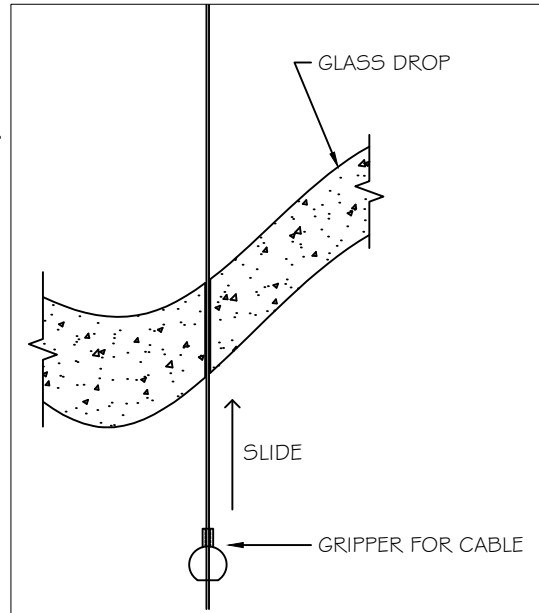
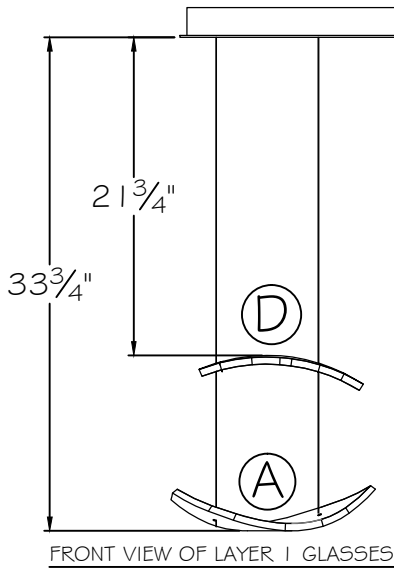
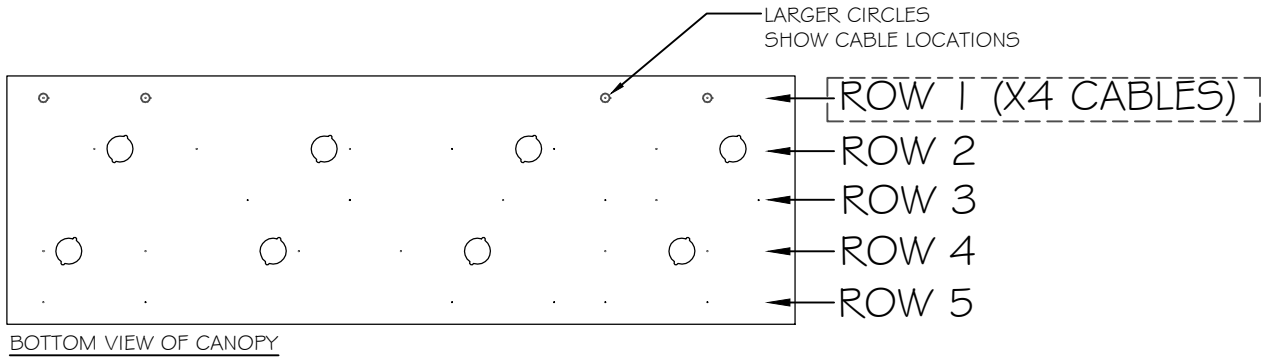

ROW 1

GLASS TYPE	QUANTITY
TYPE A	1
TYPE B	1
TYPE C	0
TYPE D	1

- FIRST ROW OF GLASSES TO BE INSTALLED IS ROW 1.
- GATHER ALL OTHER CABLES TO THE SIDE TO EASILY ACCESS LAYER TO BE WORKED ON
- LETTERS IN CIRCLES ON DIAGRAM INDICATE GLASS TYPE THAT CORRESPONDS TO STICKERS ON GLASS
- START SLIDING GLASSES UP INTO POSITION AS SHOWN ON FRONT VIEW, STARTING FROM TOP TO BOTTOM
- SLIDE GRIPPER UP TO HOLD POSITION OF GLASS
- NOTE: MULTIPLE GLASSES MAY USE THE SAME CABLES

STYLE(S) #: 894840-112 -212 -122 -222



This drawing, specifications and the product depicted are the exclusive property of Fine Art Handcrafted Lighting®. In compliance with US copyright and patent requirements, notice is hereby given that this document and the product depicted shall not be copied, altered or used in any manner without the expressed written consent of Fine Art Handcrafted Lighting®.

www.finearthl.com Tel:(305) 821-3850 Fax:(305) 513-5736
FINE ART LAMPS®

INSTRUCTION #:
00791406

SHEET
2 / 7

INSTRUCTIONS for PLUME GLASS OPTIONS

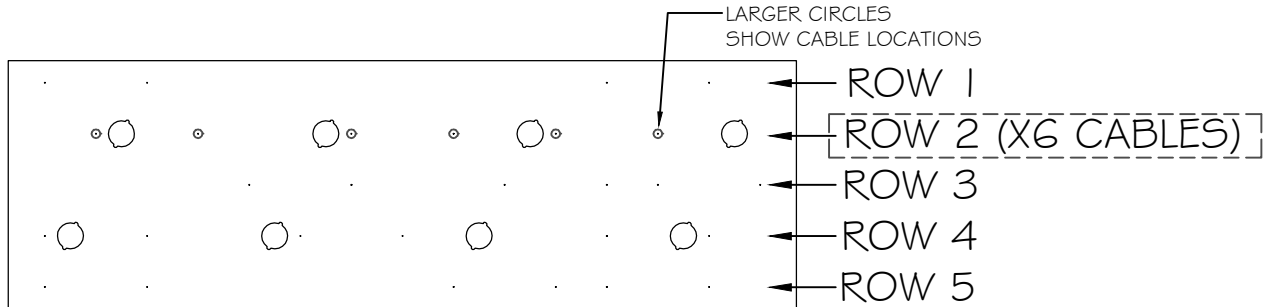

BOTTOM VIEW OF CANOPY

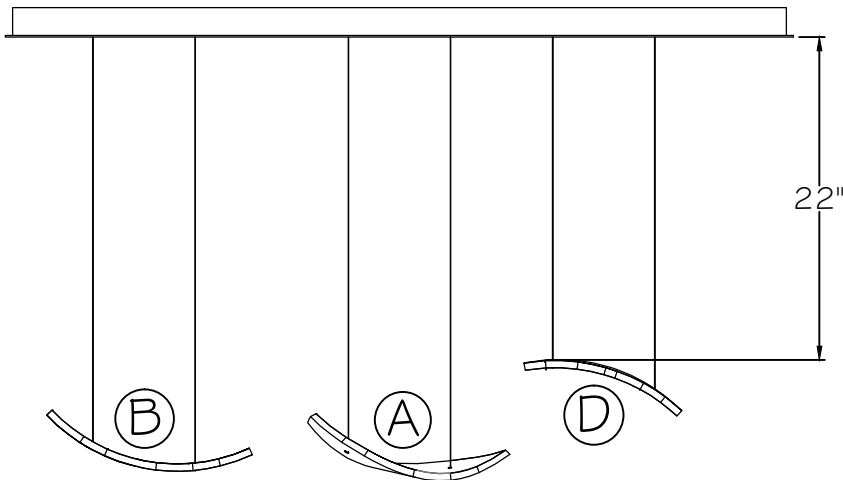

FRONT VIEW OF LAYER 2 GLASSES

ROW 2	
GLASS TYPE	QUANTITY
TYPE A	1
TYPE B	1
TYPE C	0
TYPE D	1

- NEXT ROW OF GLASSES TO BE INSTALLED IS ROW 2.
- START SLIDING GLASSES UP INTO POSITION AS SHOWN ON FRONT VIEW, STARTING FROM TOP TO BOTTOM
- SLIDE GRIPPER UP TO HOLD POSITION OF GLASS
- NOTE: MULTIPLE GLASSES MAY USE THE SAME CABLES

STYLE(S) #: 894840-112 -212 -122 -222



This drawing, specifications and the product depicted are the exclusive property of Fine Art Handcrafted Lighting®. In compliance with US copyright and patent requirements, notice is hereby given that this document and the product depicted shall not be copied, altered or used in any manner without the expressed written consent of Fine Art Handcrafted Lighting®.

www.finearthl.com

Tel:(305) 821-3850
FINE ART LAMPS®

Fax:(305) 513-5736

INSTRUCTION #:

00791406

SHEET

3 / 7

INSTRUCTIONS for PLUME GLASS OPTIONS

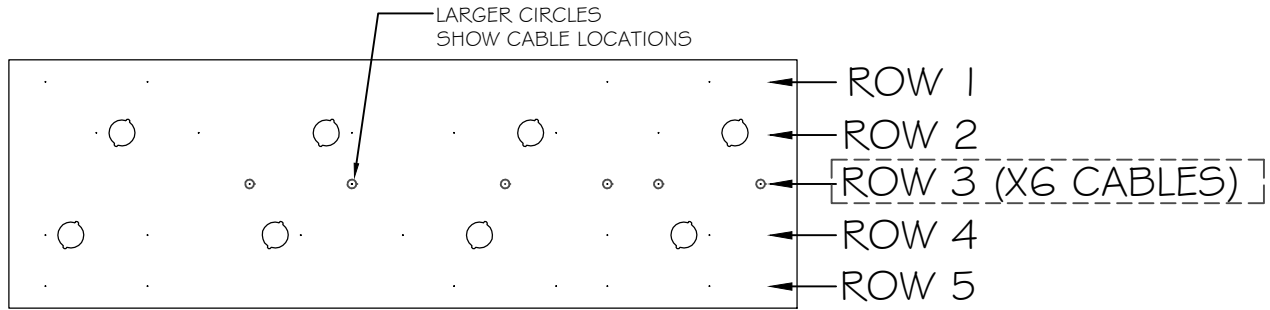

BOTTOM VIEW OF CANOPY

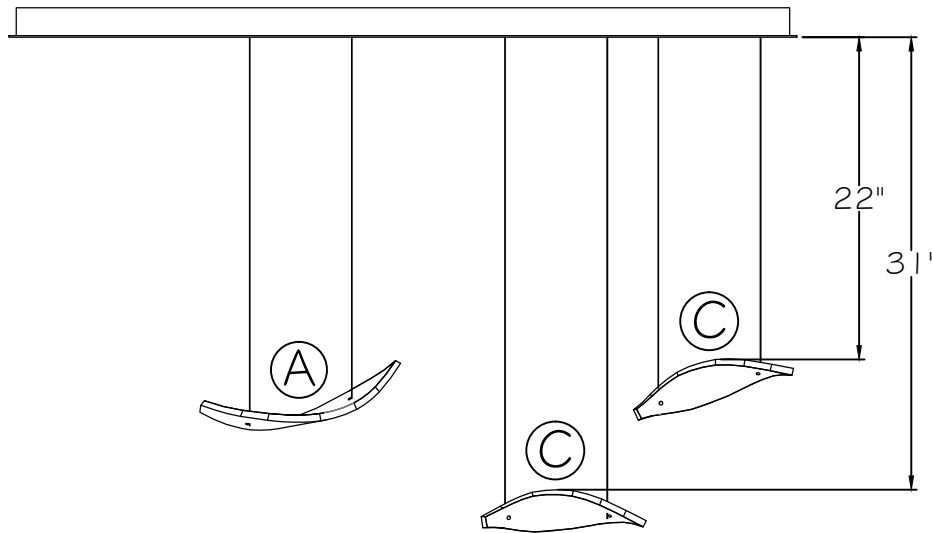

FRONT VIEW OF LAYER 3 GLASSES

ROW 3	
GLASS TYPE	QUANTITY
TYPE A	1
TYPE B	0
TYPE C	2
TYPE D	0

- NEXT ROW OF GLASSES TO BE INSTALLED IS ROW 3.
- START SLIDING GLASSES UP INTO POSITION AS SHOWN ON FRONT VIEW, STARTING FROM TOP TO BOTTOM
- SLIDE GRIPPER UP TO HOLD POSITION OF GLASS
- NOTE: MULTIPLE GLASSES MAY USE THE SAME CABLES

STYLE(S) #: 894840-112 -212 -122 -222



This drawing, specifications and the product depicted are the exclusive property of Fine Art Handcrafted Lighting®. In compliance with US copyright and patent requirements, notice is hereby given that this document and the product depicted shall not be copied, altered or used in any manner without the expressed written consent of Fine Art Handcrafted Lighting®.

www.finearthl.com

Tel:(305) 821-3850
FINE ART LAMPS®

Fax:(305) 513-5736

INSTRUCTION #:

00791406

SHEET

4 / 7

INSTRUCTIONS for PLUME GLASS OPTIONS

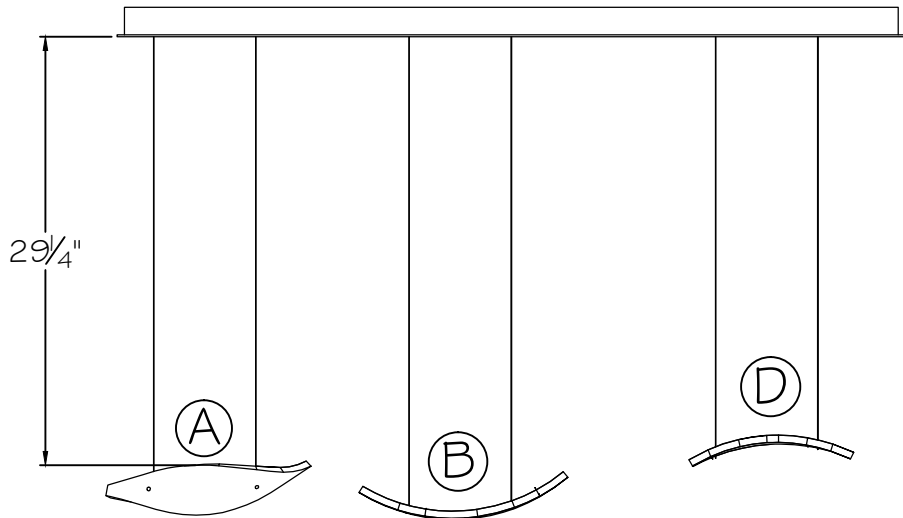
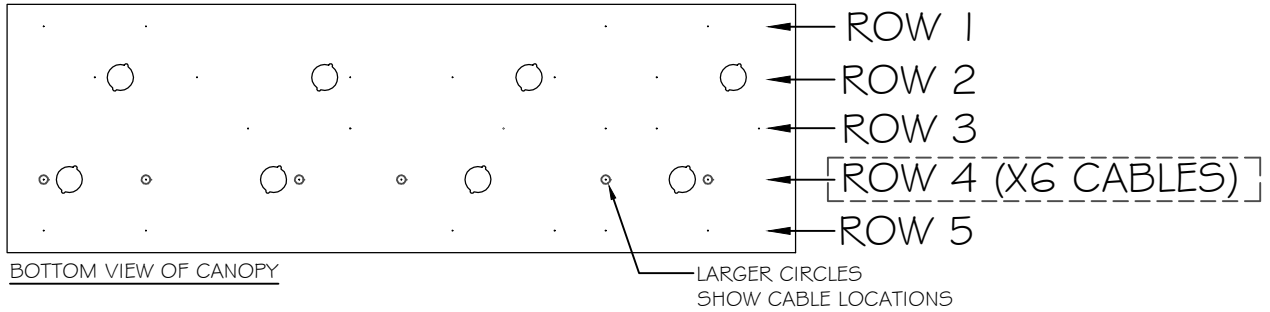

ROW 4	
GLASS TYPE	QUANTITY
TYPE A	1
TYPE B	1
TYPE C	0
TYPE D	1

- NEXT ROW OF GLASSES TO BE INSTALLED IS ROW 4.
- START SLIDING GLASSES UP INTO POSITION AS SHOWN ON FRONT VIEW, STARTING FROM TOP TO BOTTOM
- SLIDE GRIPPER UP TO HOLD POSITION OF GLASS
- NOTE: MULTIPLE GLASSES MAY USE THE SAME CABLES

STYLE(S) #: 894840-112 -212 -122 -222



This drawing, specifications and the product depicted are the exclusive property of Fine Art Handcrafted Lighting®. In compliance with US copyright and patent requirements, notice is hereby given that this document and the product depicted shall not be copied, altered or used in any manner without the expressed written consent of Fine Art Handcrafted Lighting®.

www.finearthl.com Tel:(305) 821-3850 Fax:(305) 513-5736
FINE ART LAMPS®

INSTRUCTION #:
00791406
SHEET
5 / 7

INSTRUCTIONS for PLUME GLASS OPTIONS

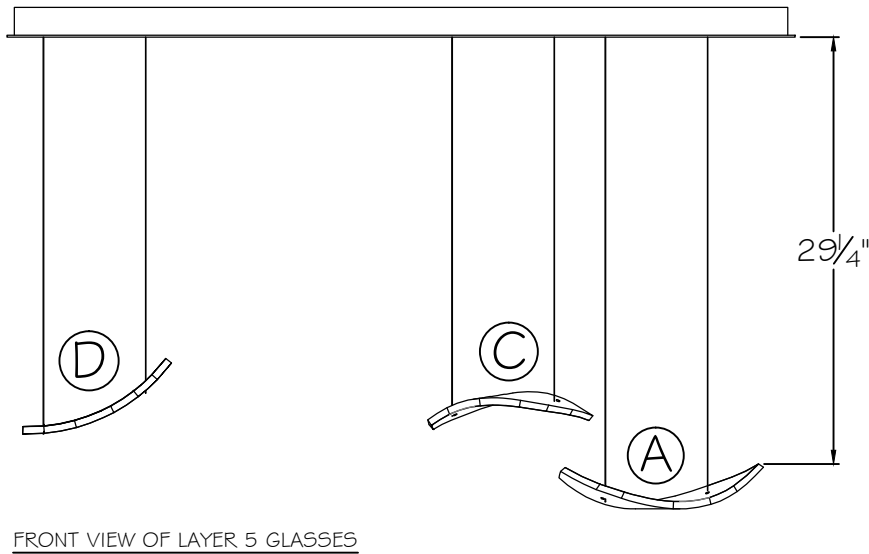
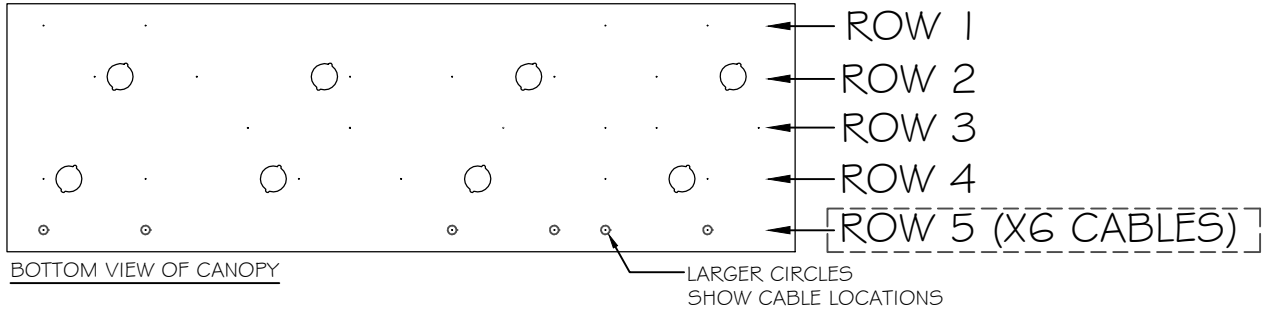

ROW 5	
GLASS TYPE	QUANTITY
TYPE A	1
TYPE B	0
TYPE C	1
TYPE D	1

- NEXT ROW OF GLASSES TO BE INSTALLED IS ROW 5.
- START SLIDING GLASSES UP INTO POSITION AS SHOWN ON FRONT VIEW, STARTING FROM TOP TO BOTTOM
- SLIDE GRIPPER UP TO HOLD POSITION OF GLASS
- NOTE: MULTIPLE GLASSES MAY USE THE SAME CABLES

STYLE(S) #: 894840-112 -212 -122 -222



This drawing, specifications and the product depicted are the exclusive property of Fine Art Handcrafted Lighting®. In compliance with US copyright and patent requirements, notice is hereby given that this document and the product depicted shall not be copied, altered or used in any manner without the expressed written consent of Fine Art Handcrafted Lighting®.

www.finearthl.com

Tel:(305) 821-3850
FINE ART LAMPS®

Fax:(305) 513-5736

INSTRUCTION #:

00791406

SHEET

6 / 7

INSTRUCTIONS for PLUME GLASS OPTIONS

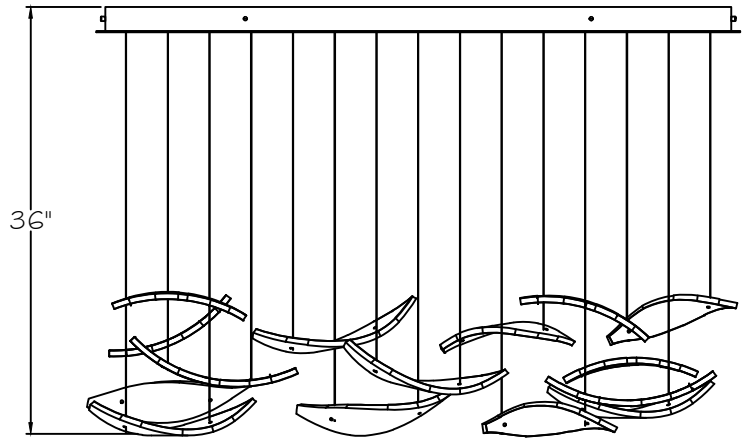
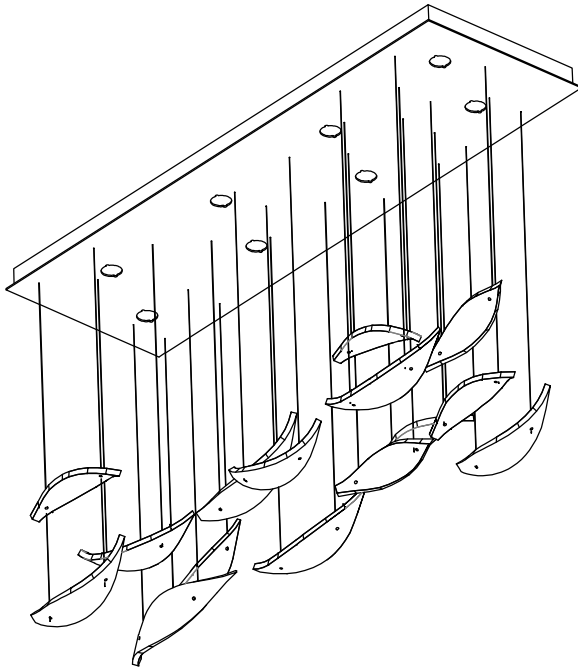

- ONCE ALL GLASSES ARE INSTALLED AND FINAL GLASS POSITION IS ACHIEVED, ENSURE TO CUT EXCESS CABLES UP TO HARDWARE OF LOWEST GLASSES. REFERENCE INSTALLATION INSTRUCTION.

STYLE(S) #: 894840-112 -212 -122 -222



This drawing, specifications and the product depicted are the exclusive property of Fine Art Handcrafted Lighting®. In compliance with US copyright and patent requirements, notice is hereby given that this document and the product depicted shall not be copied, altered or used in any manner without the expressed written consent of Fine Art Handcrafted Lighting®.

www.finearthl.com

Tel:(305) 821-3850
FINE ART LAMPS®

Fax:(305) 513-5736

INSTRUCTION #:

00791406

SHEET

7 / 7

NOTE:ORIENTATION OF CANOPY IS CRITICAL TO GLASS DROP DESIGN

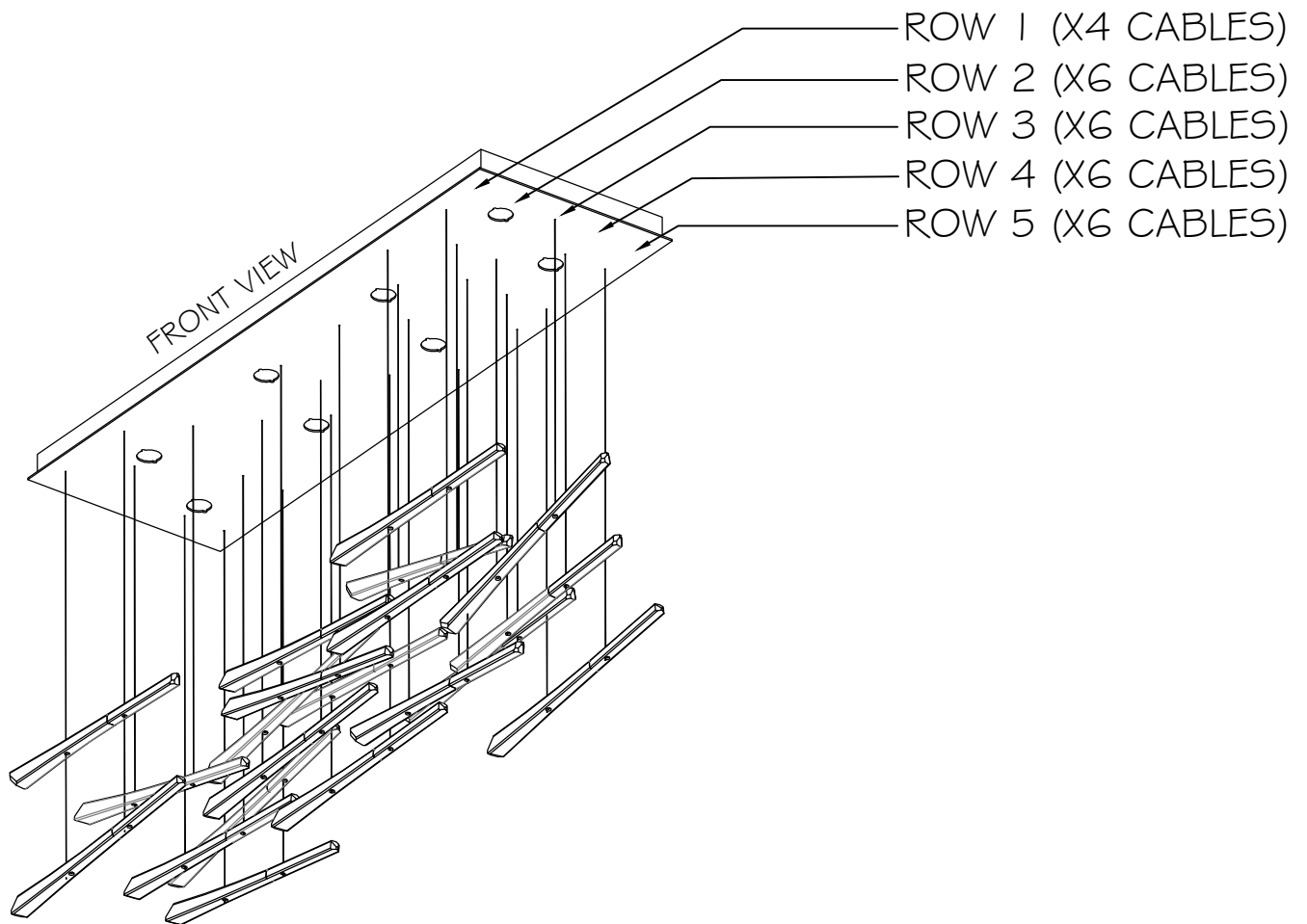

STYLE(S) #: 894840-132 -232 -142 -242 -152 -252



This drawing, specifications and the product depicted are the exclusive property of Fine Art Handcrafted Lighting®. In compliance with US copyright and patent requirements, notice is hereby given that this document and the product depicted shall not be copied, altered or used in any manner without the expressed written consent of Fine Art Handcrafted Lighting®.

www.finearthl.com

Tel:(305) 821-3850
FINE ART LAMPS®

Fax:(305) 513-5736

INSTRUCTION #:

00791409

SHEET

1 / 7

INSTRUCTIONS for SPIRE GLASS OPTIONS

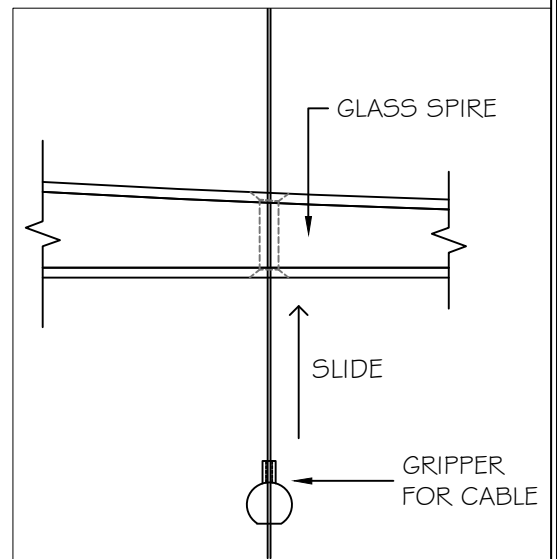
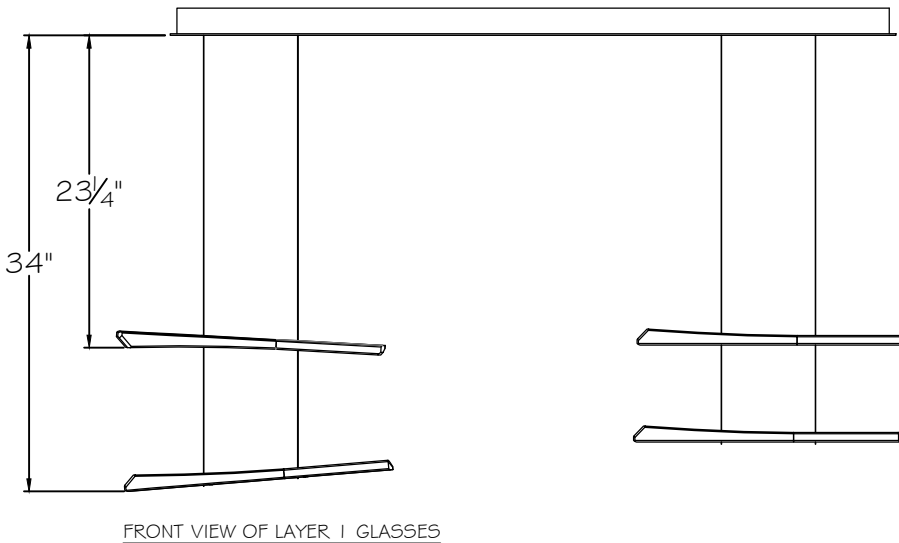
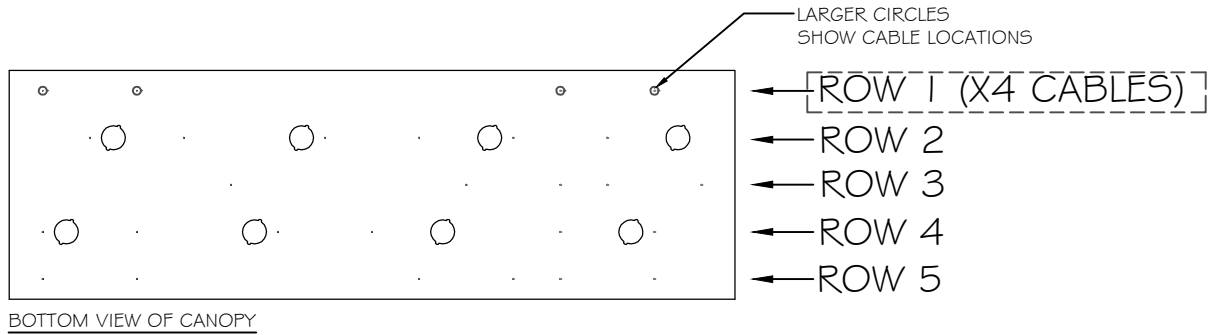

- FIRST ROW OF GLASSES TO BE INSTALLED IS ROW 1.
- GATHER ALL OTHER CABLES TO THE SIDE TO EASILY ACCESS LAYER TO BE WORKED ON
- START SLIDING GLASSES UP INTO POSITION AS SHOWN ON FRONT VIEW, STARTING FROM TOP TO BOTTOM
- SLIDE GRIPPER UP TO HOLD POSITION OF GLASS
- NOTE: MULTIPLE GLASSES MAY USE THE SAME CABLES

STYLE(S) #: 894840-132 -232 -142 -242 -152 -252



This drawing, specifications and the product depicted are the exclusive property of Fine Art Handcrafted Lighting®. In compliance with US copyright and patent requirements, notice is hereby given that this document and the product depicted shall not be copied, altered or used in any manner without the expressed written consent of Fine Art Handcrafted Lighting®.

www.finearthl.com

Tel:(305) 821-3850
FINE ART LAMPS®

Fax:(305) 513-5736

INSTRUCTION #:

00791409

SHEET

2 / 7

INSTRUCTIONS for SPIRE GLASS OPTIONS

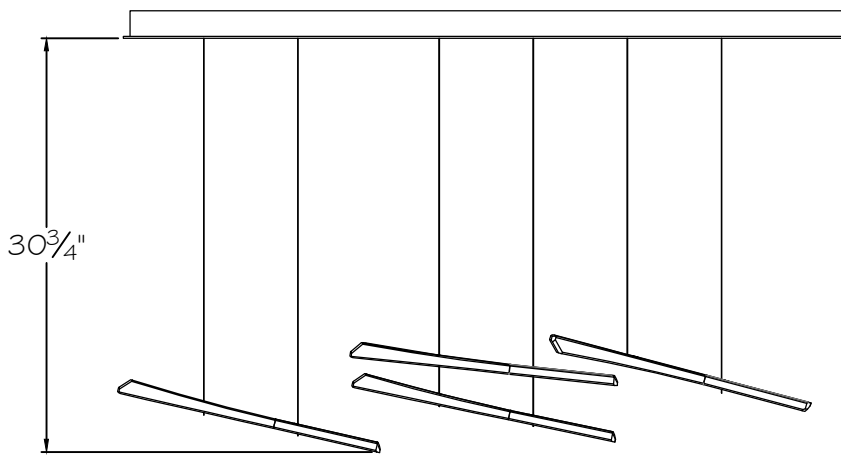
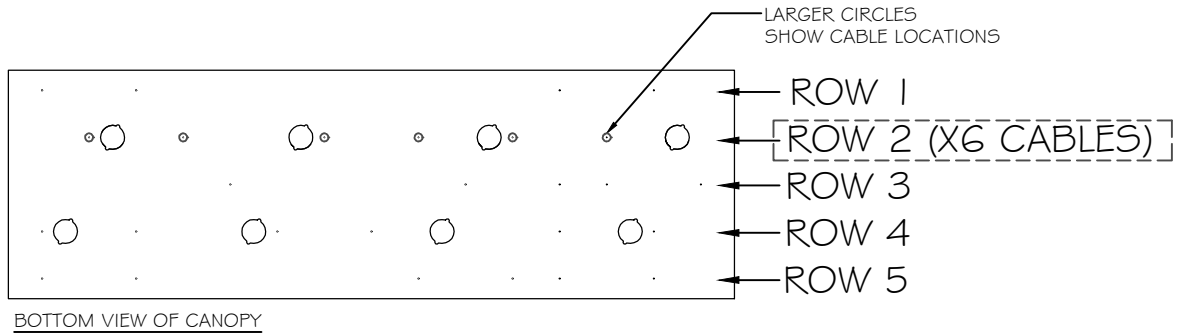

- NEXT ROW OF GLASSES TO BE INSTALLED IS ROW 2.
- START SLIDING GLASSES UP INTO POSITION AS SHOWN ON FRONT VIEW, STARTING FROM TOP TO BOTTOM
- SLIDE GRIPPER UP TO HOLD POSITION OF GLASS
- NOTE: MULTIPLE GLASSES MAY USE THE SAME CABLES

STYLE(S) #: 894840-132 -232 -142 -242 -152 -252



This drawing, specifications and the product depicted are the exclusive property of Fine Art Handcrafted Lighting®. In compliance with US copyright and patent requirements, notice is hereby given that this document and the product depicted shall not be copied, altered or used in any manner without the expressed written consent of Fine Art Handcrafted Lighting®.

www.finearthl.com

Tel:(305) 821-3850
FINE ART LAMPS®

Fax:(305) 513-5736

INSTRUCTION #:

00791409

SHEET

3 / 7

INSTRUCTIONS for SPIRE GLASS OPTIONS

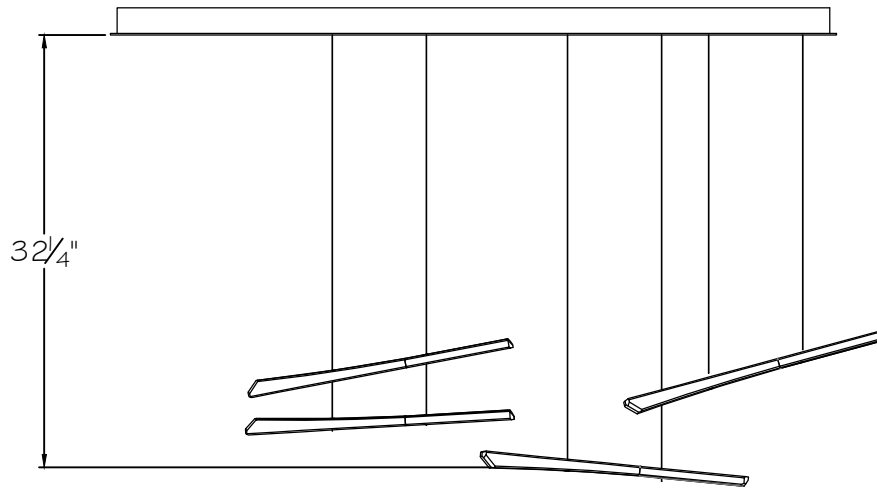
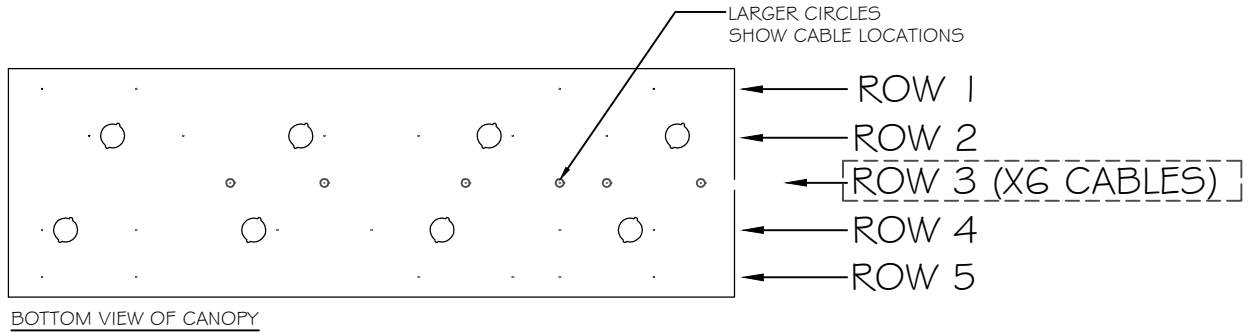

- NEXT ROW OF GLASSES TO BE INSTALLED IS ROW 3.
- START SLIDING GLASSES UP INTO POSITION AS SHOWN ON FRONT VIEW, STARTING FROM TOP TO BOTTOM
- SLIDE GRIPPER UP TO HOLD POSITION OF GLASS
- NOTE: MULTIPLE GLASSES MAY USE THE SAME CABLES

STYLE(S) #: 894840-132 -232 -142 -242 -152 -252



This drawing, specifications and the product depicted are the exclusive property of Fine Art Handcrafted Lighting®. In compliance with US copyright and patent requirements, notice is hereby given that this document and the product depicted shall not be copied, altered or used in any manner without the expressed written consent of Fine Art Handcrafted Lighting®.

www.finearthl.com

Tel:(305) 821-3850
FINE ART LAMPS®

Fax:(305) 513-5736

INSTRUCTION #:

00791409

SHEET

4 / 7

INSTRUCTIONS for SPIRE GLASS OPTIONS

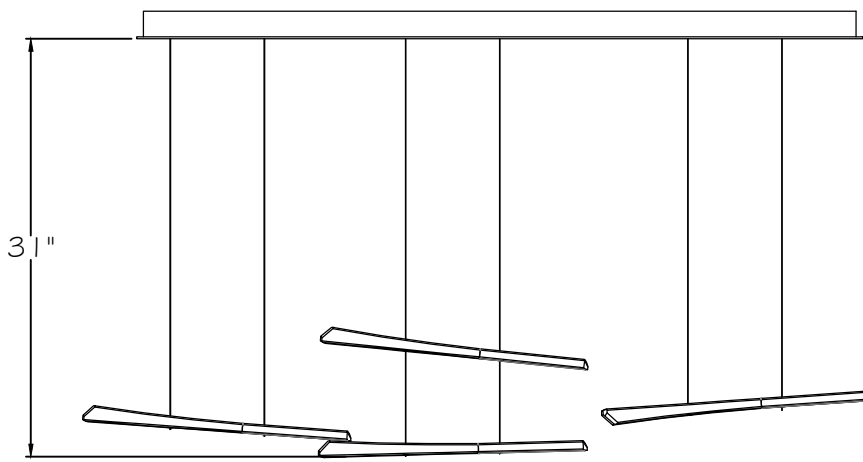
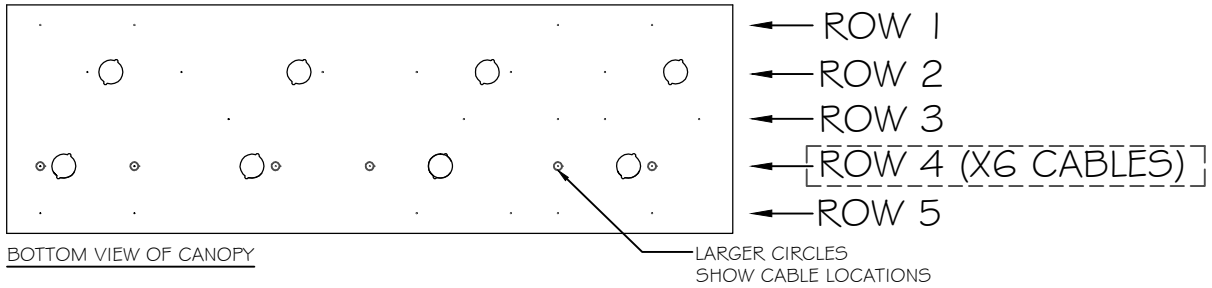

FRONT VIEW OF LAYER 4 GLASSES

- NEXT ROW OF GLASSES TO BE INSTALLED IS ROW 4.
- START SLIDING GLASSES UP INTO POSITION AS SHOWN ON FRONT VIEW, STARTING FROM TOP TO BOTTOM
- SLIDE GRIPPER UP TO HOLD POSITION OF GLASS
- NOTE: MULTIPLE GLASSES MAY USE THE SAME CABLES

STYLE(S) #: 894840-132 -232 -142 -242 -152 -252



This drawing, specifications and the product depicted are the exclusive property of Fine Art Handcrafted Lighting®. In compliance with US copyright and patent requirements, notice is hereby given that this document and the product depicted shall not be copied, altered or used in any manner without the expressed written consent of Fine Art Handcrafted Lighting®.

www.finearthl.com

Tel:(305) 821-3850
 FINE ART LAMPS®

Fax:(305) 513-5736

INSTRUCTION #:

00791409

SHEET

5 / 7

INSTRUCTIONS for SPIRE GLASS OPTIONS

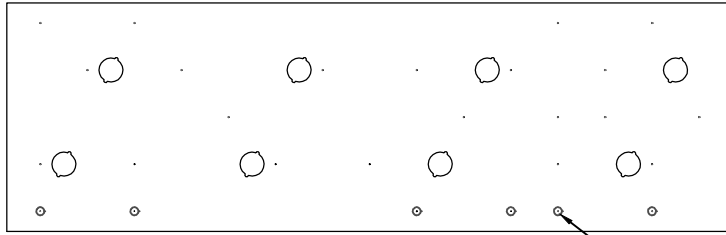

BOTTOM VIEW OF CANOPY

- ← ROW 1
- ← ROW 2
- ← ROW 3
- ← ROW 4
- ← [ROW 5 (X6 CABLES)]

LARGER CIRCLES
SHOW CABLE LOCATIONS

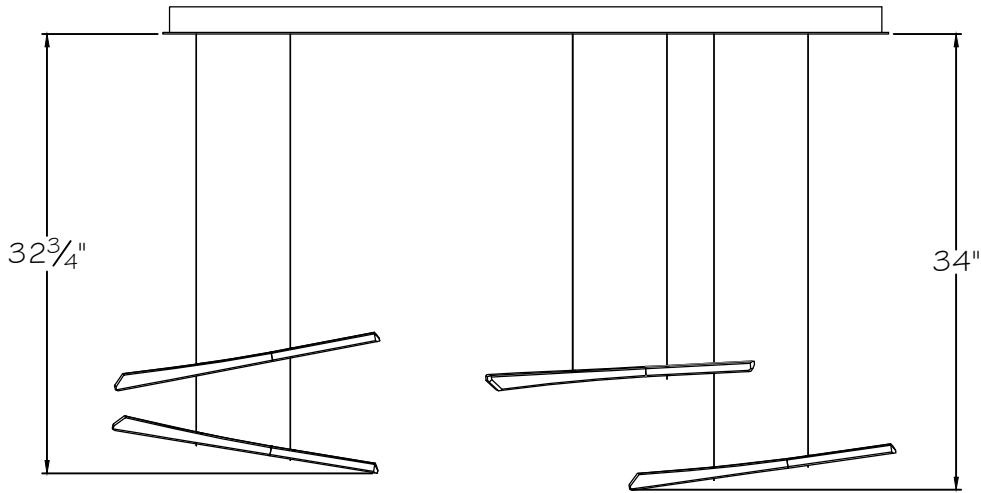

FRONT VIEW OF LAYER 5 GLASSES

- NEXT ROW OF GLASSES TO BE INSTALLED IS ROW 5.
- START SLIDING GLASSES UP INTO POSITION AS SHOWN ON FRONT VIEW, STARTING FROM TOP TO BOTTOM
- SLIDE GRIPPER UP TO HOLD POSITION OF GLASS
- NOTE: MULTIPLE GLASSES MAY USE THE SAME CABLES

STYLE(S) #: 894840-132 -232 -142 -242 -152 -252



This drawing, specifications and the product depicted are the exclusive property of Fine Art Handcrafted Lighting®. In compliance with US copyright and patent requirements, notice is hereby given that this document and the product depicted shall not be copied, altered or used in any manner without the expressed written consent of Fine Art Handcrafted Lighting®.

www.finearthl.com

Tel:(305) 821-3850
FINE ART LAMPS®

Fax:(305) 513-5736

INSTRUCTION #:

00791409

SHEET

6 / 7

INSTRUCTIONS for SPIRE GLASS OPTIONS

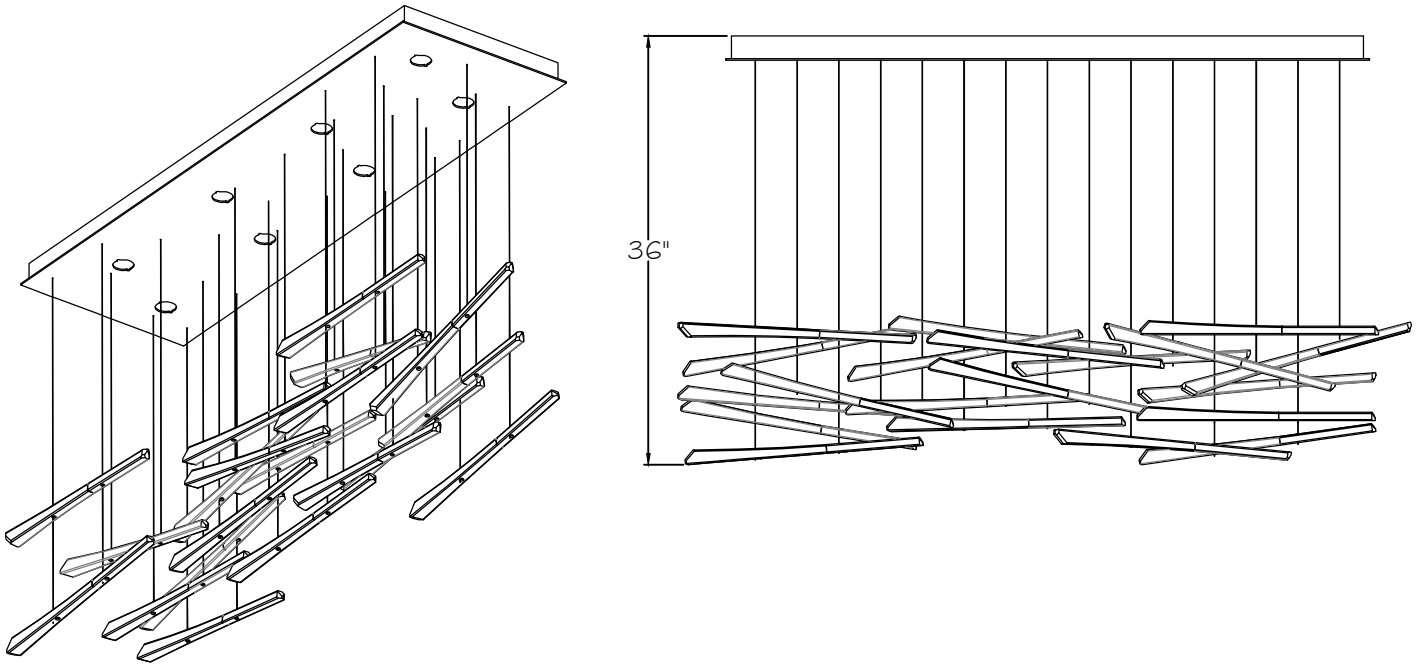

- ONCE ALL GLASSES ARE INSTALLED AND FINAL GLASS POSITION IS ACHIEVED, ENSURE TO CUT EXCESS CABLES UP TO HARDWARE OF LOWEST GLASSES. REFERENCE INSTALLATION INSTRUCTION.

STYLE(S) #: 894840-132 -232 -142 -242 -152 -252



This drawing, specifications and the product depicted are the exclusive property of Fine Art Handcrafted Lighting®. In compliance with US copyright and patent requirements, notice is hereby given that this document and the product depicted shall not be copied, altered or used in any manner without the expressed written consent of Fine Art Handcrafted Lighting®.

www.finearthl.com

Tel:(305) 821-3850
FINE ART LAMPS®

Fax:(305) 513-5736

INSTRUCTION #:

00791409

SHEET

7 / 7

NOTE: ORIENTATION OF CANOPY IS CRITICAL TO GLASS DROP DESIGN

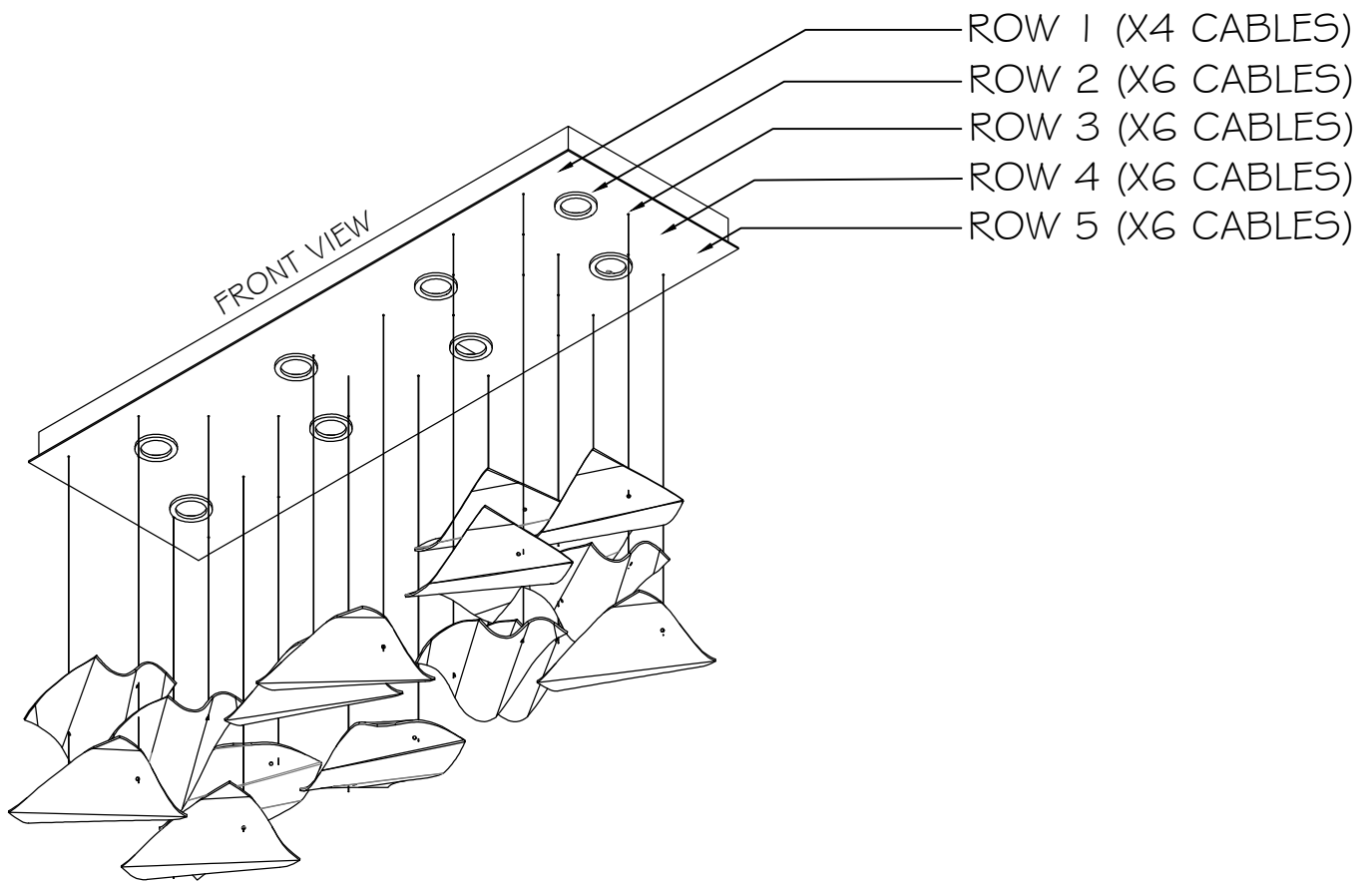

- ROW 1 (X4 CABLES)
- ROW 2 (X6 CABLES)
- ROW 3 (X6 CABLES)
- ROW 4 (X6 CABLES)
- ROW 5 (X6 CABLES)

STYLE(S) #: 894840-162 -262 -172 -272



This drawing, specifications and the product depicted are the exclusive property of Fine Art Handcrafted Lighting®. In compliance with US copyright and patent requirements, notice is hereby given that this document and the product depicted shall not be copied, altered or used in any manner without the expressed written consent of Fine Art Handcrafted Lighting®.

www.finearthl.com

Tel: (305) 821-3850
FINE ART LAMPS®

Fax: (305) 513-5736

INSTRUCTION #:

00791494

SHEET

1 / 7

INSTRUCTIONS for PAGES GLASS OPTIONS

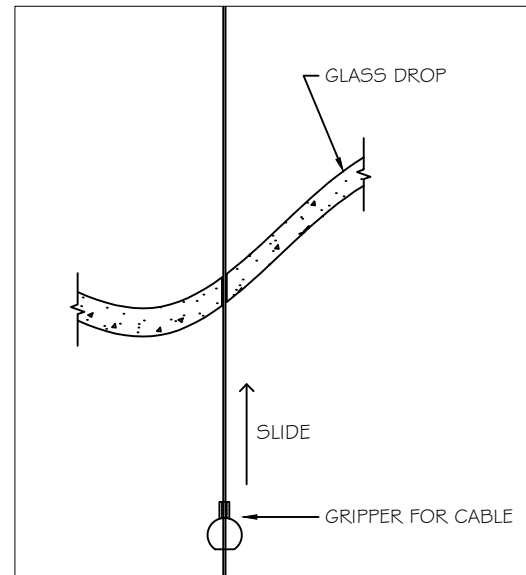
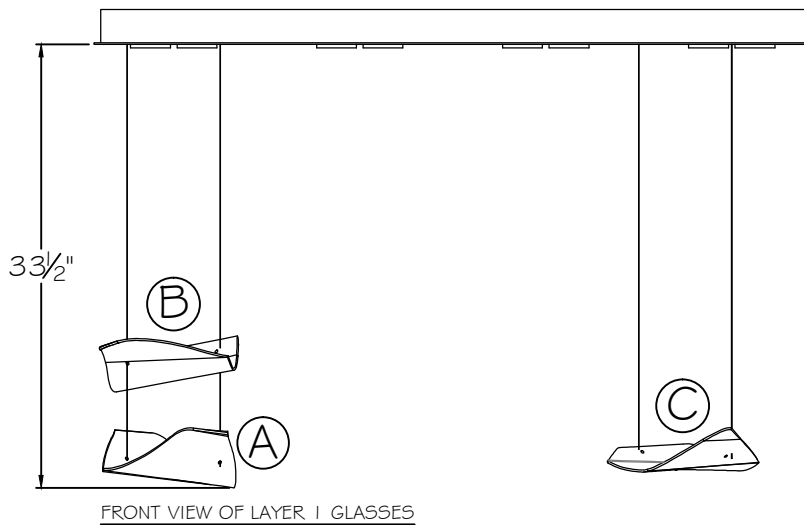
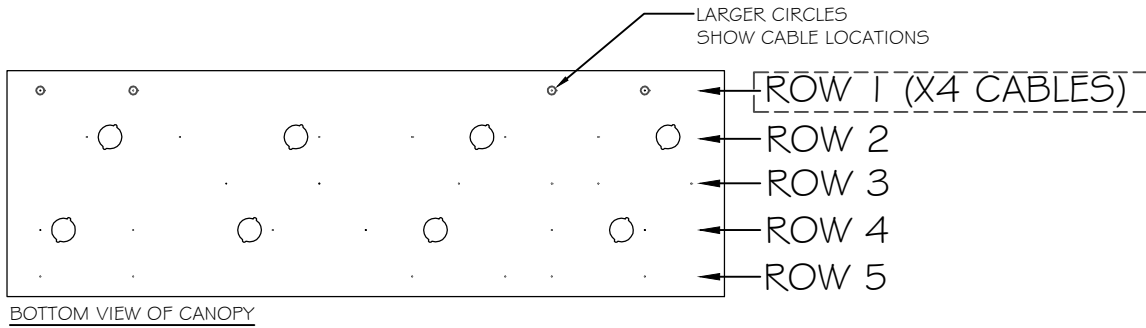

ROW 1

GLASS TYPE	QUANTITY
TYPE A	1
TYPE B	1
TYPE C	1

- FIRST ROW OF GLASSES TO BE INSTALLED IS ROW 1.
- GATHER ALL OTHER CABLES TO THE SIDE TO EASILY ACCESS LAYER TO BE WORKED ON
- LETTERS IN CIRCLES ON DIAGRAM INDICATE GLASS TYPE THAT CORRESPONDS TO STICKERS ON GLASS
- START SLIDING GLASSES UP INTO POSITION AS SHOWN ON FRONT VIEW, STARTING FROM TOP TO BOTTOM
- SLIDE GRIPPER UP TO HOLD POSITION OF GLASS
- NOTE: MULTIPLE GLASSES MAY USE THE SAME CABLES

STYLE(S) #: 894840-162 -262 -172 -272



This drawing, specifications and the product depicted are the exclusive property of Fine Art Handcrafted Lighting®. In compliance with US copyright and patent requirements, notice is hereby given that this document and the product depicted shall not be copied, altered or used in any manner without the expressed written consent of Fine Art Handcrafted Lighting®.

www.finearthl.com

Tel:(305) 821-3850
FINE ART LAMPS®

Fax:(305) 513-5736

INSTRUCTION #:

00791494

SHEET

2 / 7

INSTRUCTIONS for PAGES GLASS OPTIONS

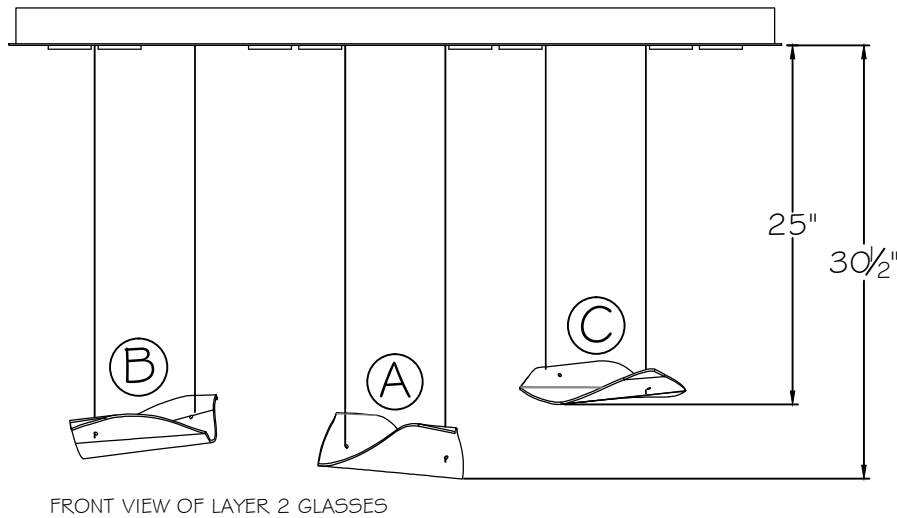
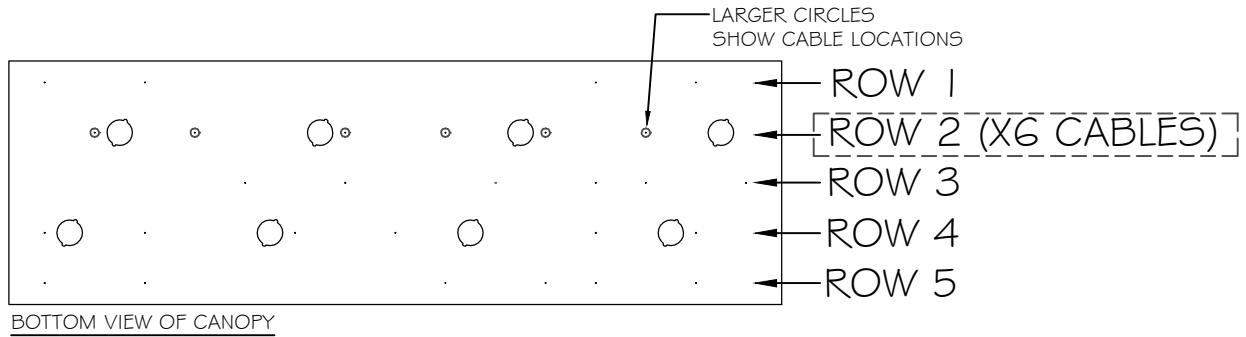

ROW 2	
GLASS TYPE	QUANTITY
TYPE A	1
TYPE B	1
TYPE C	1
<ul style="list-style-type: none"> - NEXT ROW OF GLASSES TO BE INSTALLED IS ROW 2. - START SLIDING GLASSES UP INTO POSITION AS SHOWN ON FRONT VIEW, STARTING FROM TOP TO BOTTOM - SLIDE GRIPPER UP TO HOLD POSITION OF GLASS - NOTE: MULTIPLE GLASSES MAY USE THE SAME CABLES 	

STYLE(S) #: 894840-162 -262 -172 -272



This drawing, specifications and the product depicted are the exclusive property of Fine Art Handcrafted Lighting®. In compliance with US copyright and patent requirements, notice is hereby given that this document and the product depicted shall not be copied, altered or used in any manner without the expressed written consent of Fine Art Handcrafted Lighting®.

www.finearthl.com

Tel:(305) 821-3850
FINE ART LAMPS®

Fax:(305) 513-5736

INSTRUCTION #:

00791494

SHEET

3 / 7

INSTRUCTIONS for PAGES GLASS OPTIONS

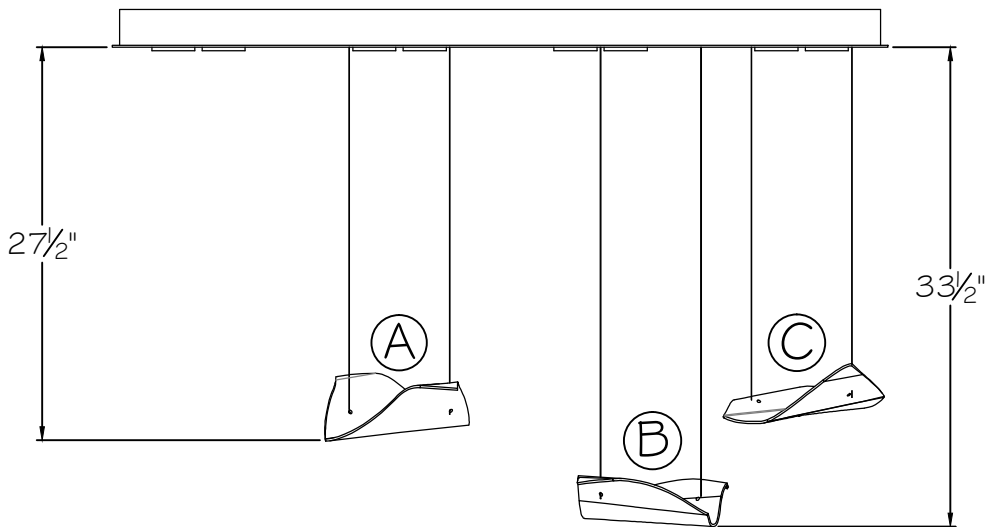
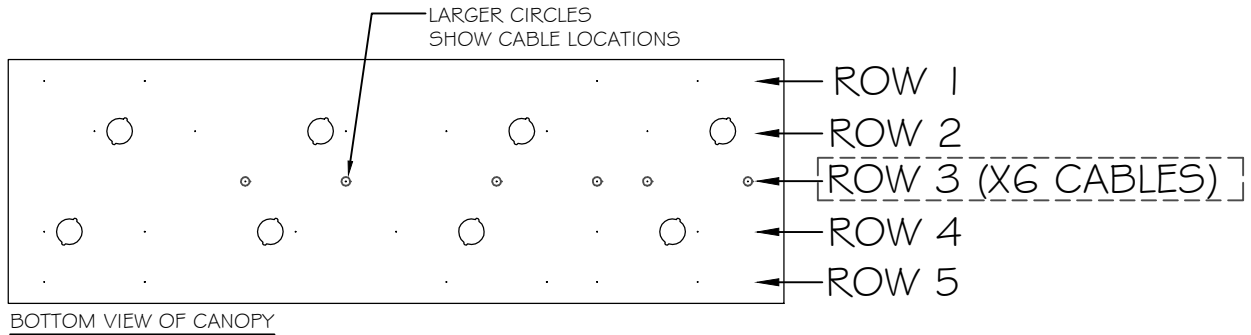

ROW 3	
GLASS TYPE	QUANTITY
TYPE A	1
TYPE B	1
TYPE C	1

- NEXT ROW OF GLASSES TO BE INSTALLED IS ROW 3.
- START SLIDING GLASSES UP INTO POSITION AS SHOWN ON FRONT VIEW, STARTING FROM TOP TO BOTTOM
- SLIDE GRIPPER UP TO HOLD POSITION OF GLASS
- NOTE: MULTIPLE GLASSES MAY USE THE SAME CABLES

STYLE(S) #: 894840-162 -262 -172 -272



This drawing, specifications and the product depicted are the exclusive property of Fine Art Handcrafted Lighting®. In compliance with US copyright and patent requirements, notice is hereby given that this document and the product depicted shall not be copied, altered or used in any manner without the expressed written consent of Fine Art Handcrafted Lighting®.

www.finearthl.com

Tel:(305) 821-3850
FINE ART LAMPS®

Fax:(305) 513-5736

INSTRUCTION #:

00791494

SHEET

4 / 7

INSTRUCTIONS for PAGES GLASS OPTIONS

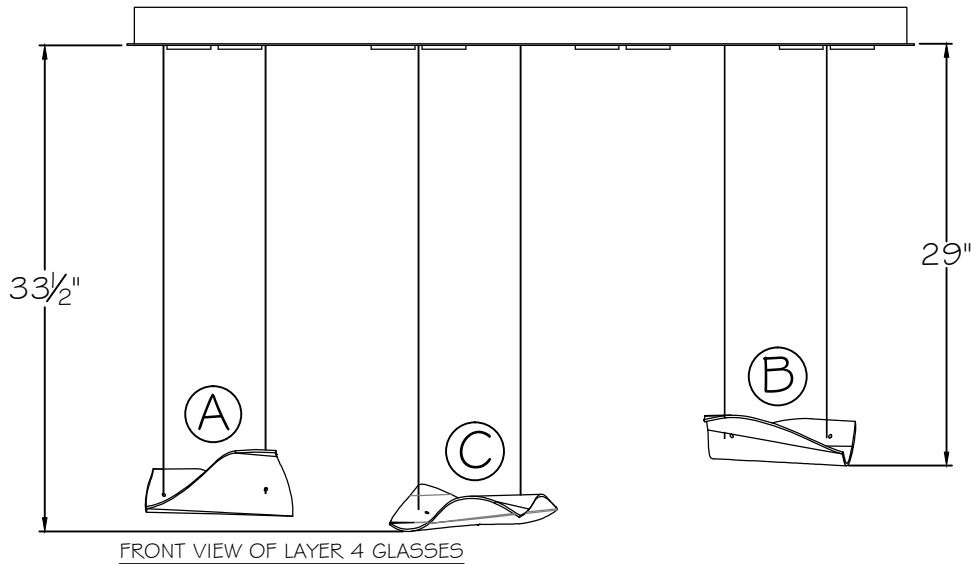
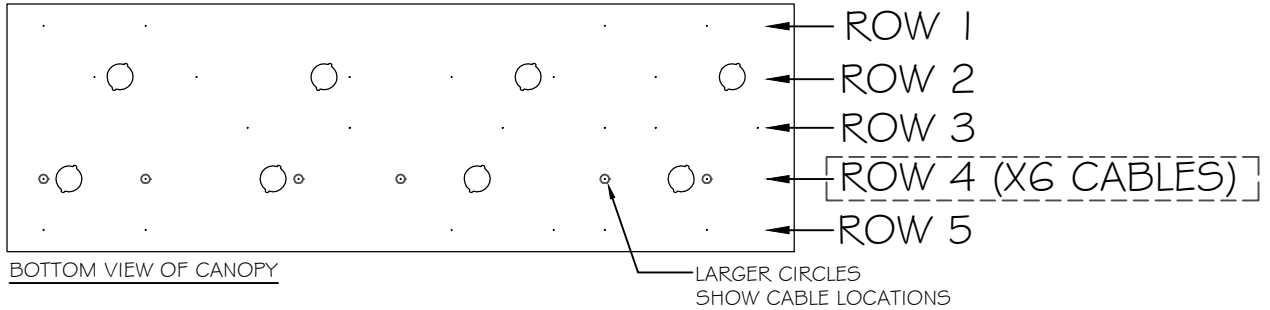

ROW 4	
GLASS TYPE	QUANTITY
TYPE A	1
TYPE B	1
TYPE C	1
<ul style="list-style-type: none"> - NEXT ROW OF GLASSES TO BE INSTALLED IS ROW 4. - START SLIDING GLASSES UP INTO POSITION AS SHOWN ON FRONT VIEW, <u>STARTING FROM TOP TO BOTTOM</u> - SLIDE GRIPPER UP TO HOLD POSITION OF GLASS - NOTE: MULTIPLE GLASSES MAY USE THE SAME CABLES 	

STYLE(S) #: 894840-162 -262 -172 -272



This drawing, specifications and the product depicted are the exclusive property of Fine Art Handcrafted Lighting®. In compliance with US copyright and patent requirements, notice is hereby given that this document and the product depicted shall not be copied, altered or used in any manner without the expressed written consent of Fine Art Handcrafted Lighting®.

www.finearthl.com

Tel:(305) 821-3850
FINE ART LAMPS®

Fax:(305) 513-5736

INSTRUCTION #:

00791494

SHEET

5 / 7

INSTRUCTIONS for PAGES GLASS OPTIONS

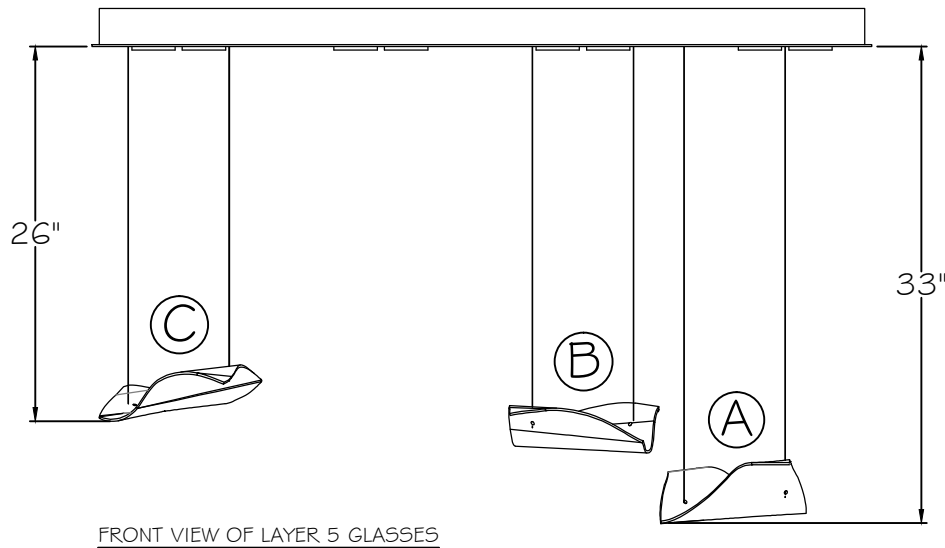
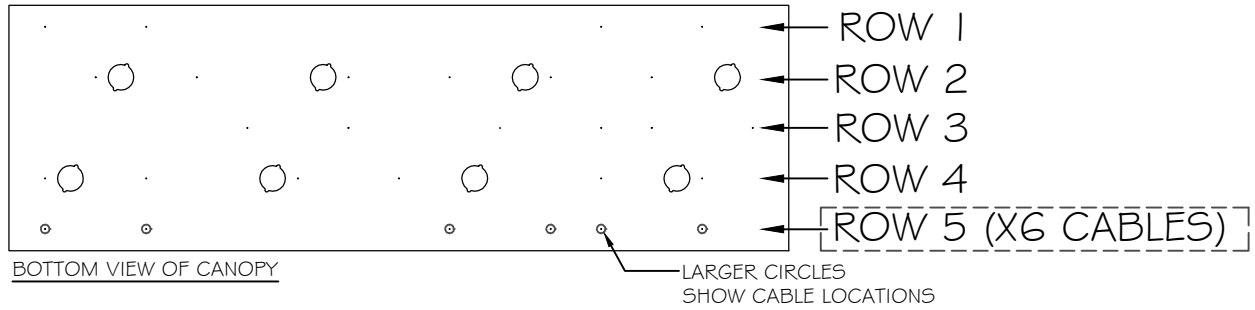

ROW 5	
GLASS TYPE	QUANTITY
TYPE A	1
TYPE B	1
TYPE C	1
<ul style="list-style-type: none"> - NEXT ROW OF GLASSES TO BE INSTALLED IS ROW 5. - START SLIDING GLASSES UP INTO POSITION AS SHOWN ON FRONT VIEW, <u>STARTING FROM TOP TO BOTTOM</u> - <u>SLIDE GRIPPER UP TO HOLD POSITION OF GLASS</u> - NOTE: MULTIPLE GLASSES MAY USE THE SAME CABLES 	

STYLE(S) #: 894840-162 -262 -172 -272



This drawing, specifications and the product depicted are the exclusive property of Fine Art Handcrafted Lighting®. In compliance with US copyright and patent requirements, notice is hereby given that this document and the product depicted shall not be copied, altered or used in any manner without the expressed written consent of Fine Art Handcrafted Lighting®.

www.finearthl.com

Tel:(305) 821-3850
FINE ART LAMPS®

Fax:(305) 513-5736

INSTRUCTION #:

00791494

SHEET

6 / 7

INSTRUCTIONS for PAGES GLASS OPTIONS

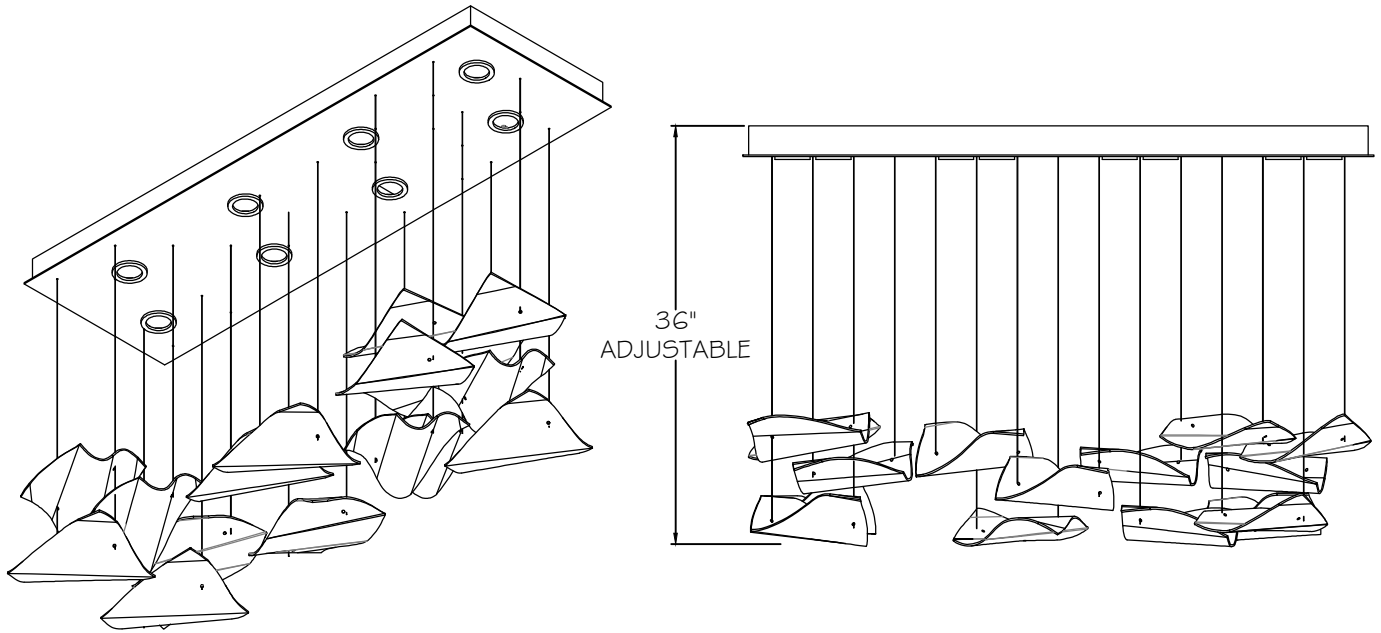

- ONCE ALL GLASSES ARE INSTALLED AND FINAL GLASS POSITION IS ACHIEVED, ENSURE TO CUT EXCESS CABLES UP TO HARDWARE OF LOWEST GLASSES. REFERENCE INSTALLATION INSTRUCTION.

STYLE(S) #: 894840-162 -262 -172 -272



This drawing, specifications and the product depicted are the exclusive property of Fine Art Handcrafted Lighting®. In compliance with US copyright and patent requirements, notice is hereby given that this document and the product depicted shall not be copied, altered or used in any manner without the expressed written consent of Fine Art Handcrafted Lighting®.

www.finearthl.com

Tel:(305) 821-3850
FINE ART LAMPS®

Fax:(305) 513-5736

INSTRUCTION #:

00791494

SHEET

7 / 7